



Low Voltage Low Power DTMOS-CDTA Filter Design Using for Biomedical Signal Processing Applications

Melih YILDIRIM^{1*}, Hatice Gül UGRANLI², Firat KAÇAR³

¹Bitlis Eren University, Department of Electrical-Electronics Engineering, 13000, Bitlis-Turkey

²Bartın University, Department of Electrical-Electronics Engineering, 74110, Bartın-Turkey

³Istanbul University, Department of Electrical-Electronics Engineering, 34320, Istanbul-Turkey

* Corresponding Author : myildirim@beu.edu.tr

(First received 15 November 2016 and in final form 30 December 2016)

Presented in "3rd International Conference on Computational and Experimental Science and Engineering (ICCESSEN-2016)"

Keywords

Current Differencing
Transconductance Amplifier
Dynamic Threshold Voltage
MOSFET
Biomedical Signal Processing
Active Filter
Electrocardiograph

Abstract: In this work, a band pass filter circuit consisting of Current Differencing Transconductance Amplifier (CDTA) structure, working in the biomedical signal frequency range, is proposed and simulation results are obtained via LTSPICE program. PMOS transistors in the proposed CDTA filter circuit are made with Dynamic Threshold Voltage MOS (DTMOS) structures instead of traditional MOSFETs. LTSPICE simulations of the proposed circuits give results that agree well with the ideal results. The proposed CDTA filter circuit thanks to the usage of DTMOS transistors operates at a supply voltages of $\pm 0.4V$ and power dissipation is approximately 90nW.

1. Introduction

Devices with less power dissipation have an important place for the researchers as battery capacity is a major problem. Studies for producing devices with minor power consumption have been increasingly conducted for the last decades. Because of this reason, the main purpose of this study is to have analogue circuit working under the very low power and low symmetrical supply voltage. The threshold voltage of MOSFET in the analogue blocks utilizing for biomedical signal processing can be decreased by use of DTMOS transistor structure. By this way, decreasing of the supply voltage required and less power dissipation can be provided.

Current mode circuits are preferred to voltage mode circuits due to their advantages like higher bandwidth, better linearity, simpler topology, less power consumption, less supply voltage requirement and higher slew rate [1]. In this work, CDTA circuit, a current mode circuit structure, was simulated using CMOS 0.18 μm TSMC process parameter. CDTA circuit [2] and filter structure carried out in the previous studies was utilized. In

the paper [2], simulated CDTA circuit operated at a supply voltages of $\pm 2.5V$ and power dissipation was approximately 4.4mW. However, in this work differently from other studies DTMOS structure was tested for CDTA circuit. Hereby, the proposed active filter circuit is performed with less supply voltage and minimized power consumption in comparison with the previous papers.

2. DTMOS-CDTA Circuit Topology

The designed circuit consists a current differencing circuit in the input stage and an OTA (Operational Transconductance Amplifier) circuit in the output stage [3]. CDTA symbol is shown in Figure 1. The current of the terminal-Z is equal to the difference of the input currents, I_p and I_n . The voltage V_z is multiplied by a transconductance to yield a current output from terminal-X as $\pm gmV_z$. I_{x+} and I_{x-} display the output currents. The formula for CDTA circuit is given by equation 1.

$$V_p = V_n = 0; I_z = I_p - I_n; I_{x+} = gmV_z; I_{x-} = -gmV_z \quad (1)$$

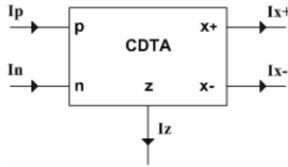

Figure 1. CDTA Symbol

As it is known the idea of conventional MOSFET structure is to connect body and source of transistor. Figure 2 displays a DTMOS structure. The crucial important advantage of using a DTMOS structure is to minimize the threshold voltage so that the circuit can economize power dissipation consuming from the supply [4-6].

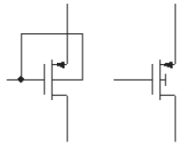

Figure 2. DTMOS Transistor and Its Symbol

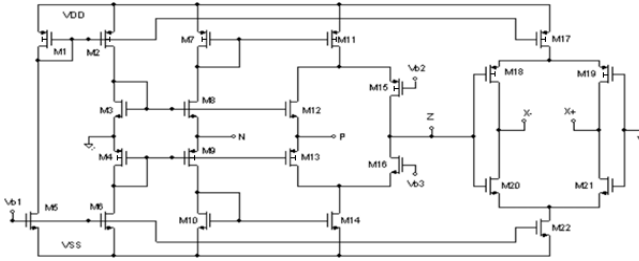

Figure 3. CDTA Circuit

Table 1. The Aspect Ratios of MOSFETs

$M_1=120u/1u$	$M_2=120u/1u$	$M_3=100u/1u$	$M_4=100u/1u$
$M_5=120u/1u$	$M_6=120u/1u$	$M_7=500u/1u$	$M_8=200u/1u$
$M_9=200u/1u$	$M_{10}=500u/1u$	$M_{11}=500u/1u$	$M_{12}=100u/1u$
$M_{13}=100u/1u$	$M_{14}=500u/1u$	$M_{15}=300u/1u$	$M_{16}=300u/1u$
$M_{17}=40u/1u$	$M_{18}=600u/1u$	$M_{19}=600u/1u$	$M_{20}=50u/1u$
$M_{21}=50u/1u$	$M_{22}=46u/1u$		

3. Simulation Results

DC and AC characteristics of CDTA circuit, simulated with using TSMC 0.18 um proses parameter in LTSPICE, are given in the following figures.

As can be seen in Figure 3 all PMOSs were implemented as DTMOS. The purpose of this is to decrease threshold voltage of MOSFET. In this way, voltages less than 0.4V were enough to work the filter circuit. The proposed circuit operated at a supply voltages of $\pm 0.4V$ (V_{DD} and V_{SS}). The bias voltages V_{b1} , V_{b2} and V_{b3} were selected as $-0.25V$, $0.04V$ and $-0.08V$, respectively. Table 1 displays the aspect ratios of MOSFETs. As seen in Table 1, due to the fact that current flowing through DTMOS is lower in comparison to that of

conventional MOSFET, the aspect ratios of transistor are selected bigger [7].

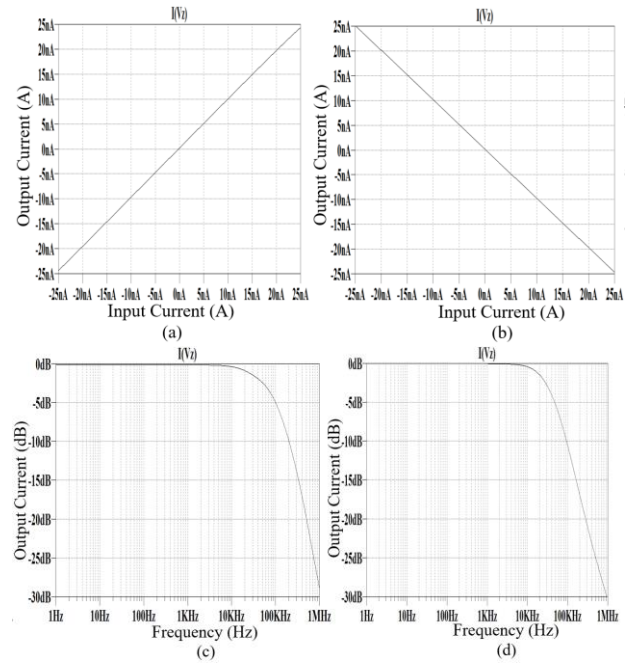

Figure 4. DC Analysis for Input Stage: (a) $I_z=I_p-I_n$ (I_p variable, $I_n=0$) (b) $I_z=I_p-I_n$ (I_n variable, $I_p=0$) AC Analysis for Input Stage: (c) $I_z=I_p-I_n$ (I_p variable, $I_n=0$) (d) $I_z=I_p-I_n$ (I_n variable, $I_p=0$)

As shown in Figure 4 DC and AC analyses for input stage showed that simulation results correspond well with ideal results. Filter can function properly for input currents between $\pm 25nA$.

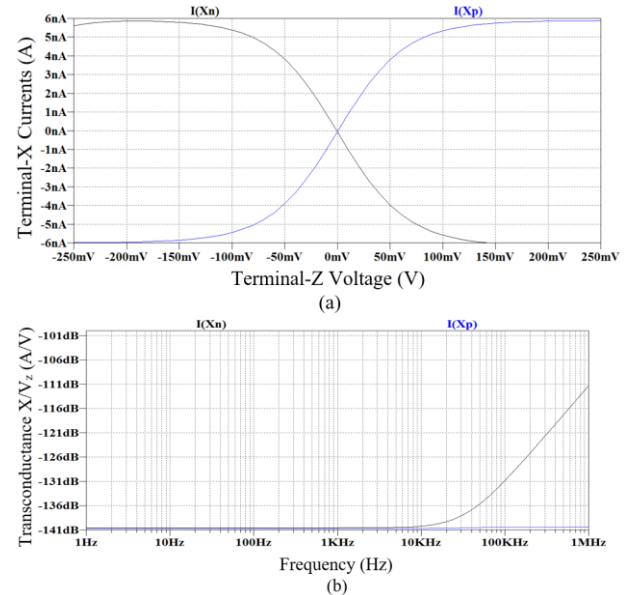

Figure 5. (a) DC Analysis for Output Stage (b) AC Analysis for Output Stage (X_p/V_z , X_n/V_z)

According to DC analysis of output stage it can be clearly seen that a current output from X terminal is obtained as $\pm gmV_z$. In addition to this, it is shown in Figure 4 and 5 that this filter circuit has an

approximately 10KHz bandwidth and the transconductance value of output stage is calculated as 93nA/V or -140.5dB.

4. DTMOS Active Filter Circuit

The main aim of using transistors with DTMOS structure is due to its suitability for filter circuits using in biomedical signal processing in the low frequency range and requiring low power dissipation. A filter circuit with low pass, band pass and high pass filter characteristics working in ECG (electrocardiogram) signal frequency range was simulated to prove that DTMOS structure is suitable for biomedical signals. Figure 6 (a) shows CDTA filter circuit [8] and Figure 6 (b) displays the implemented filter circuit via LTSPICE program. Circuit components C_1 , C_2 and R were selected as 2nF, 0.2nF and 1Kohm, respectively. Frequency response of the proposed DTMOS-CDTA filter circuit is given in Figure 7.

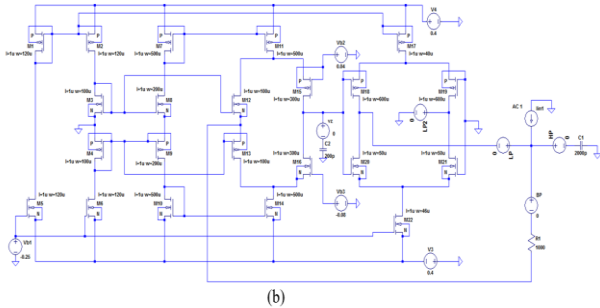
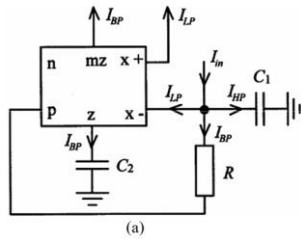

Figure 6. (a) CDTA Filter Circuit (b) Implemented Filter Circuit via LTSPICE Program

The transfer functions of CDTA filter circuit are as indicated below,

$$\begin{aligned} \frac{I_{BP}}{I_{in}} &= \frac{\frac{s}{RC_1}}{s^2 + \frac{s}{RC_1} + \frac{g_m}{RC_1C_2}} \\ \frac{I_{LP}}{I_{in}} &= \frac{\frac{g_m}{RC_1C_2}}{s^2 + \frac{s}{RC_1} + \frac{g_m}{RC_1C_2}} \\ \frac{I_{HP}}{I_{in}} &= \frac{s^2}{s^2 + \frac{s}{RC_1} + \frac{g_m}{RC_1C_2}} \end{aligned} \quad (2)$$

Natural frequency ω_0 , quality factor Q and bandwidth B are as follows,

$$\omega_0 = \sqrt{\frac{g_m}{RC_1C_2}}; \quad Q = \sqrt{g_mR\frac{C_1}{C_2}}; \quad B = \frac{1}{RC_1} \quad (3)$$

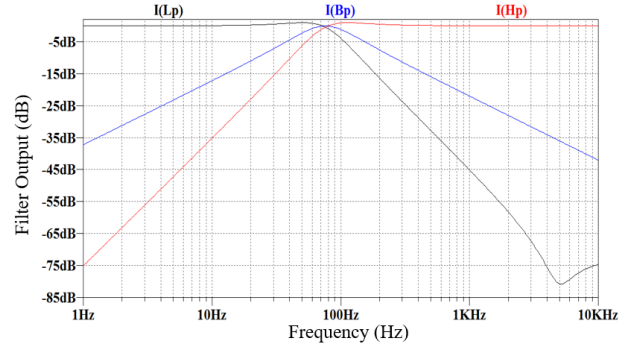

Figure 7. Frequency Response of the Proposed DTMOS-CDTA Filter Circuit

Frequency response of low-pass, high-pass and band-stop filters for 1Hz-10 KHz frequency range is shown in Figure 7. This result corresponds well with the design intentions. 3dB cut-off frequencies for band pass filter output are 45 Hz and 125 Hz. This frequency range can be changed depending on the value of capacitors and resistor. Due to ECG signal has a frequency range between 0.3 and 150 Hz, this filter is quite suitable for ECG signal processing applications.

5. Results

In this paper, a filter simulation consisting of CDTA structure, working in biomedical signal frequency range, was implemented. Normally, capacitor value for filter circuit without DTMOS structure should be high to make circuit work in the low frequency range. However, using DTMOS transistor provided circuit to function properly with smaller value capacitor and lower supply voltage. Battery capacity issue, which is a major problem for mobile devices, can be suppressed with use of DTMOS structure. In addition to this, small valued capacitor can cause circuit area to be smaller with comparison to traditional MOSFET circuit area. Simulation results showed that these results have been obtained using only $\pm 0.4V$ supply voltage while power dissipating is only 90nW power. All LTSPICE simulations showed that ideal and simulated results are found in close agreement. It is expected that the proposed filter circuit will be useful in various low voltage low power current-mode analogue signal-processing applications.

References

[1] M.A. and Prem Pyari, M., "FVF based CDTA and Its application", International Conference on Communication, Information & Computing

Technology (ICCICT) (2012) 1-4 DOI:
10.1109/ICCICT.2012.6398094

- [2] Uygur, A., Kuntman, H., & Zeki, A., "Multi-input multi-output CDTA-based KHN filter", In Proc. of ELECO: The 4th International Conference on Electrical and Electronics (2005) 46-50
- [3] Basak, M.E., Kacar, F., "A New Fully Integrated High Frequency Full-Wave Rectifier Realization", Journal of Microelectronics, Electronic Components and Materials Vol. 45, No. 2 (2015)
- [4] Assaderaghi, F., Parke, S., Sinitsky, D., Bokor, J., Ko, P.K. and Chenming Hu, "A dynamic threshold voltage MOSFET (DTMOS) for very low voltage operation," Electron Device Letters, IEEE, vol.15, no.12 (1994) 510-512 DOI: 10.1109/55.338420
- [5] Uygur, A., Kuntman, H., "DTMOS-based 0.4 V ultra low-voltage low-power VDTA design and its application to EEG data processing," Radioengineering, vol.22, no.2 (2013)
- [6] Maymandi-nejad, M., Sachdev, M., "DTMOS Technique for Low-Voltage Analog Circuits," in IEEE Transactions on Very Large Scale Integration (VLSI) Systems, vol.14, no.10, (2006) 1151-1156 DOI: 10.1109/TVLSI.2006.884174
- [7] Uygur, A., H. Kuntman, An ultra low-voltage, ultra low-power DTMOS-based CCII design for speech processing filters, Proc. of ELECO 2013: The 8th International Conference on Electrical and Electronics Engineering, Bursa, Turkey (2013) 31-35
- [8] Bielek D., Biolkova V. and Kolka Z., "Current-mode biquad employing single CDTA" Indian Journal of Pure & Applied Physics. Vol. 47, (2009) 535-537